

Hyper SuperServer SYS-221H-TN24R



More details here

Key Applications

Virtualization, Software-defined Storage, AI Inference and Machine Learning, Cloud Computing, Enterprise Server,

Key Features

- Dual Socket E (LGA-4677) 5th/4th Gen Intel® Xeon® Scalable processors;
- 32 DIMM slots supporting up to 8TB of memory; RDIMMs up to DDR5-5600;
- Optional PCIe slot configurations up to 8 PCIe 5.0 x8 or 4 PCIe 5.0 x16 slots with support for double-width GPU/Accelerator cards;
- Flexible networking options with up to 2 AIOM networking slots (OCP NIC 3.0 compatible);
- 24x 2.5" hot-swap NVMe/SATA/SAS drive bays; 2x internal M.2 NVMe/SATA drive slots; Optional RAID support via storage add-on card;
- 4 heavy duty hot-swap fans with optimal fan speed control;



Form Factor	2U Rackmount Enclosure: 437 x 88.9 x 760mm (17.2" x 3.5" x 29.9") Package: 605 x 263 x 1107mm (23.8" x 10.4" x 43.6")
Processor	Dual Socket E (LGA-4677) 5th Gen Intel® Xeon®/4th Gen Intel® Xeon® Scalable processors Supports Intel Xeon CPU Max Series with high bandwidth memory (HBM) Up to 64C/128T; Up to 320MB Cache per CPU
GPU	Max GPU Count: Up to 4 double-width or 4 single-width GPU(s) Supported GPU: NVIDIA PCIe: L40S, RTX A2000, A100 CPU-GPU Interconnect: PCIe 5.0 x16 CPU-to-GPU Interconnect GPU-GPU Interconnect: PCIe
System Memory	Slot Count: 32 DIMM slots Max Memory (1DPC): Up to 4TB 5600MT/s ECC DDR5 RDIMM Max Memory (2DPC): Up to 8TB 4400MT/s ECC DDR5 RDIMM
Drive Bays	24x 2.5" hot-swap NVMe/SATA/SAS drive bays (NVMe, SATA, or SAS support requires additional parts. Please see the Optional Parts list.) 2 M.2 NVMe OR 2 M.2 SATA3 M-Key, 2280/2210
Expansion Slots	4 (Optional) PCIe 5.0 x16 or x8 FH, 10.5"L slot(s) 4 (Optional) PCIe 5.0 x8 FH, 10.5"L slot(s) Note: For 16 NVMe configurations, PCIe slots 1,2 and AIOM slot A2 cannot be used. For 24 NVMe configurations, PCIe slots 1,2,5,6 and AIOM slot A2 cannot be used.
On-Board Devices	SATA: SATA3 (6Gbps); RAID 0/1/5/10 support NVMe: NVMe; RAID 0/1/5/10 support (Intel® VROC RAID Key required) Chipset: Intel® C741 Network Connectivity: 2x 1GbE BaseT with Intel® i350-AM2 (optional) 4x 1GbE BaseT or 4x 1GbE SFP with Intel® i350-AM4 (optional) 2x 10GbE BaseT with Intel® X550-AT2 (optional) 2x 10GbE SFP+ with Intel® X710-BM2 (optional) 4x 10GbE SFP+ with Intel® XL710-BM1 (optional) 4x 10GbE RJ45/SFP+ with Intel® X710-TM4 (optional) 2x 25GbE SFP28 with Broadcom® BCM57414 (optional) 4x 25GbE RJ45/SFP28 with Mellanox® CX-4 Lx EN Intel® X550-AT2 (optional) 2x 100GbE QSFP28 with Broadcom® BCM57508 (optional) IPMI: Support for Intelligent Platform Management Interface v.2.0 IPMI 2.0 with virtual media over LAN and KVM-over-LAN support
Input / Output	LAN: 1 RJ45 Dedicated BMC LAN port USB: 2 USB 2.0 port(s) (2 rear)

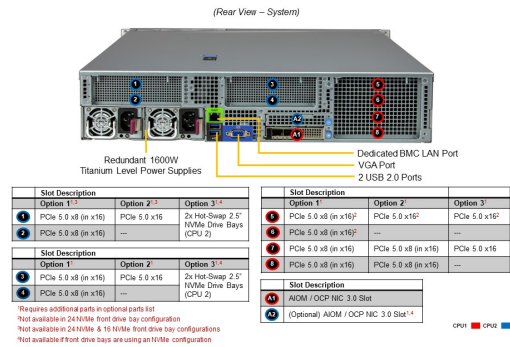
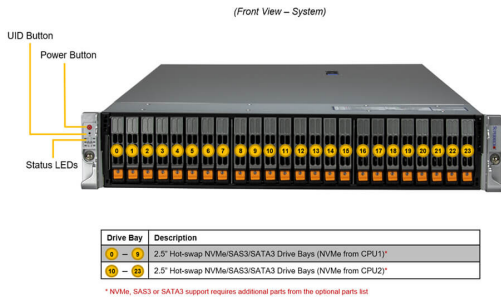

System Cooling	Fans: 4x 8cm heavy duty fans with optimal fan speed control Air Shroud: 2 Air Shroud(s) Liquid Cooling: 1Direct to Chip (D2C) Cold Plate (optional)
Power Supply	2x 1600W Redundant Titanium Level power supplies
System BIOS	BIOS Type: AMI 256MB SPI Flash
Management	Redfish API; Supermicro Server Manager (SSM); Supermicro Power Manager (SPM); Supermicro Update Manager (SUM); SuperDoctor® 5; Super Diagnostics Offline ; KVM with dedicated LAN ; IPMI 2.0
PC Health Monitoring	CPU: Monitors for CPU Cores, Chipset Voltages, Memory FAN: Fans with tachometer monitoring Status monitor for speed control Pulse Width Modulated (PWM) fan connectors Temperature: Monitoring for CPU and chassis environment Thermal Control for fan connectors
Dimensions and Weight	Height: 3.5" (88.9 mm) Width: 17.2" (437 mm) Depth: 29.9" (760 mm) Gross Weight: 66 lbs (30 kg) Net Weight: 40 lbs (18.2 kg) Packaging: 10.4" (H) x 23.8" (W) x 43.6" (D) Available Color: N/A
Operating Environment	Operating Temperature: 10°C ~ 35°C (50°F ~ 95°F) Non-operating Temperature: -40°C to 70°C (-40°F to 158°F) Operating Relative Humidity: 8% to 90% (non-condensing) Non-operating Relative Humidity: 5% to 95% (non-condensing)
Motherboard	Super X13DEM
Chassis	CSE-HS219-R1K63P