

BigTwin SuperServer SYS-221BT-DNTR



More details here

Key Applications

High-Performance File System, Diskless HPC Clusters, Scale Out All-Flash NVMe Storage, Big Data Analytics and AI,

Key Features

- Socket E (LGA 4677) support 5th/4th Gen Intel® Xeon® Scalable processors;
- Intel® C741;
- 16 DIMM Slots supporting up to 4TB of memory; ECC RDIMMs up to DDR5-5600;
- Internal PCIe 4.0 x8 for 2 M.2 NVMe support onboard; Optional M.2 NVMe Boot Controller via SCC-A2NM2241G3-B1; 1 PCIe 5.0 x16 (LP) slot; 2 PCIe 5.0 x8 (LP) slot; Tool-less support;
- Network connectivity via AIOM (OCP 3.0 compliant);
- 12 hot-Swap 2.5" drive bays (2x PCIe 5.0 NVMe/SATA and 10x PCIe 4.0 NVMe/SATA);
- 4 cooling fans per 2U enclosure, 16.5K RPM; Shared Cooling Design; Liquid Cooling Support;
- 2200W Redundant Power Supplies Titanium Level (96%+); Shared Power Design;



Form Factor	2U Rackmount Enclosure: 449 x 88 x 730mm (17.68" x 3.47" x 28.75") Package: 626 x 248 x 1150mm (24.65" x 9.76" x 45.28")
Processor	Dual Socket E (LGA-4677) 5th Gen Intel® Xeon®/4th Gen Intel® Xeon® Scalable processors Supports Intel Xeon CPU Max Series with high bandwidth memory (HBM) Up to 64C/128T; Up to 320MB Cache per CPU
GPU	Max GPU Count: Up to 1 double-width or 1 single-width GPU(s)
System Memory	Slot Count: 16 DIMM slots Max Memory (1DPC): Up to 4TB 5600MT/s ECC DDR5 RDIMM
Drive Bays	12x 2.5" hot-swap NVMe/SATA drive bays (2x PCI-E 5.0 NVMe/SATA and 10x PCI-E 4.0 NVMe/SATA) 2 M.2 NVMe
Expansion Slots	2 PCIe 5.0 x8 LP slot(s) 1 PCIe 5.0 x16 LP slot(s)
On-Board Devices	Chipset: Intel® C741 Network Connectivity: Via AIOM IPMI: Support for Intelligent Platform Management Interface v.2.0 IPMI 2.0 with virtual media over LAN and KVM-over-LAN support
Input / Output	LAN: 1 RJ45 Dedicated BMC LAN port USB: 2 USB 3.1 port(s) (2 rear) Video: 1 VGA port(s) Others: 2x M.2 for boot drive or caching M.2 form factor: NVMe double-sided 22x110mm Note: Enterprise-grade M.2 only for caching application

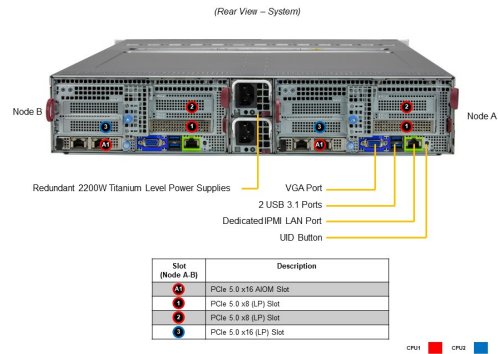
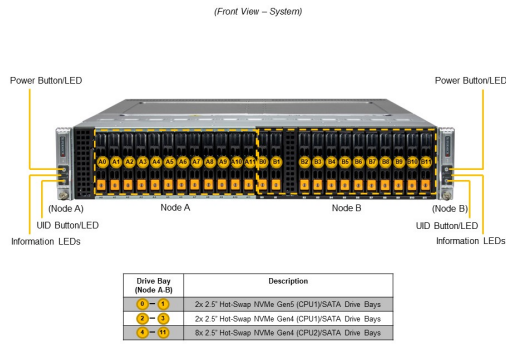

System Cooling	Fans: 4x 16.5K RPM Heavy Duty 8cm Fan(s) Liquid Cooling: 1Direct to Chip (D2C) Cold Plate (optional)
Power Supply	2200W Redundant Titanium Level power supplies
System BIOS	BIOS Type: AMI 32MB Flash ROM
Management	Redfish API; Supermicro Server Manager (SSM); Supermicro Power Manager (SPM); Supermicro Update Manager (SUM); SuperDoctor® 5; Super Diagnostics Offline ; KVM with dedicated LAN ; IPMI 2.0
PC Health Monitoring	FAN: Fans with tachometer monitoring Status monitor for speed control Pulse Width Modulated (PWM) fan connectors Temperature: Monitoring for CPU and chassis environment CPU: Monitors for CPU Cores, Chipset Voltages, Memory. 8+4 Phase-switching voltage regulator
Dimensions and Weight	Height: 3.47" (88 mm) Width: 17.68" (449 mm) Depth: 28.75" (730 mm) Gross Weight: 80.7 lbs (36.6 kg) Net Weight: 55.1 lbs (25 kg) Packaging: 9.76" (H) x 24.65" (W) x 45.28" (D) Available Color: Black front & silver body
Operating Environment	ROHS: RoHS Compliant Operating Temperature: 10°C ~ 35°C (50°F ~ 95°F) Non-operating Temperature: -30°C to 60°C (-22°F to 140°F) Operating Relative Humidity: 8% to 80% (non-condensing) Non-operating Relative Humidity: 8% to 90% (non-condensing)
Motherboard	Super X13DET-B
Chassis	CSE-217BD2-R2K22P